

Utilizing Hands-On Learning to Facilitate Progression Through Bloom's Taxonomy Within the First Semester

Ricky Castles, Vinod K. Lohani, and Pushkin Kachroo
rcastles@vt.edu, vlohani@vt.edu, pushkin@unlv.edu

Abstract – Hands-on learning has been utilized in engineering curriculums for several years in order to illustrate theory in a physical way. This paper presents the use of two hands-on learning activities in a first semester, freshman year engineering course designed to introduce basic concepts from mechanical engineering, electrical engineering, and computer engineering. In previous offerings of the course, several disjoint activities have been provided in order to introduce the fundamentals of these disciplines. This paper presents how several weeks worth of material are synthesized in a hands-on activity in order to allow deeper levels of student understanding and to showcase how engineering knowledge from a variety of disciplines can be synthesized in a meaningful way. Through these exercises students are able to understand how computer programs can be used to collect data from sensors, determine the appropriate response to this sensor data, and control circuits that are used to drive mechanical systems based on the sensor data. Through this activity, students are able to escalate through several levels of Bloom's taxonomy by drawing connections between theory and practice from a variety of fields.

Index Terms – Bloom's Taxonomy, Hands-on learning, Mechatronics, First-Year Initiatives

INTRODUCTION

Hands-on learning has the potential to introduce concepts in a manner conducive with more learning styles than a traditional lecture. Neurologists and anthropologists have found that there is a strong connection between the hand and the mind [1]. While significant learning can occur without hands-on activities, knowledge is reinforced and framed in a different context through hands-on learning allowing more students an opportunity to experience concepts and to make connections in the brain that would not be made through reading assignments or mathematical problem solving. Several educators have argued that the use of hands-on learning in the STEM disciplines is critical to gaining interest in STEM fields at a young age and is critical to compensating for the lack of interest American students have in STEM field when compared to students in several other countries [2]. In the United States only about 5% of all earned bachelor's degrees are in engineering fields while in

Asia 20% of all earned bachelor's degrees are in engineering[3].

DEPARTMENT STRUCTURE AND REFORMATION

At Virginia Tech, all first year engineering students are enrolled in a general engineering program in the Department of Engineering Education (EngE) and matriculate to one of eleven departments at the completion of their first year. All first semester engineering students take a common course designed to introduce the engineering discipline, problem solving, engineering ethics, design, and various introductory technical skills such as data plotting and analysis, computer programming, and multi-view drawing. In 2004, the Department of Engineering Education, in collaboration with the Department of Biological Systems Engineering(BSE) and the Center for Excellence in Undergraduate Teaching began a major NSF sponsored transformation in the first year engineering curriculum. This work was funded by a Department Level Reform (DLR) grant[4] and was based strongly on the concept of a spiral curriculum which was first introduced in 1960 by Jerome Bruner[5]. The idea of the spiral curriculum is to introduce a concept and then to revisit that concept at a later time at a higher level in order to reinforce knowledge previously introduced and to expand on a topic several times as a student journeys through a curriculum. The partnership between the EngE department and the BSE department allowed material to be introduced to students in their first year in the EngE department and to be exposed to more advanced presentations of similar material as upperclassmen in the BSE department.

As part of this initiative, the curriculum and format in the freshman engineering program was significantly changed. Prior to this initiative, first semester engineering students met with a faculty member for two 50-minute lectures each week. The course primarily included traditional instruction through lecture and problem solving. Hands-on activities were introduced through projects completed outside the classroom and very little hands-on learning was including within the weekly course meetings. Since the DLR, one of the 50-minute weekly lectures has been replaced by a 90-minute graduate student led hands-on workshop. The workshops are primarily intended to be a synthesis of a recitation and a laboratory and encourage review of lecture material along with experiential learning. Students participate in various team-based hands-on

October 18 - 21, 2009, San Antonio, TX

activities each week in order to learn more about the various engineering disciplines and professional practice. This paper focuses on the development of several hands-on activities designed to introduce the fundamentals of computer programming, digital logic, mechanics, and electrical circuits.

HANDS-ON ACTIVITIES

In Spring 2006 a mechatronics activity was developed to introduce the basics of mechanics and circuit theory. After a lecture on basic principles such as voltage, current, torque, angular velocity, and Boolean logic, students participated in a hands-on activity involving the assembly of a simple mobile robot. In this activity, students work in pairs to assemble a gearbox and then build a motor driver circuit that is used to control the wheels on the gearbox. Students learned to identify and understand the utility of various circuit components including resistors, integrated circuits, capacitors, switches, voltage regulators, and diodes. A multimeter was also provided to each pair of students so they could ensure that each stage of the circuit was behaving properly before proceeding to the next stage of circuit building. The circuit was divided into three stages with the first stage being to interface a 9V battery and a switch with a breadboard, the second stage being to use the voltage converter to step the input voltage down to 5V, and the third stages was to make all the proper connections on an h-bridge motor driver chip. Figure 1 shows the mobile robot that the students built in the mechatronics hands-on workshop. Figure 2 shows the pseudo-schematic provided to the students to assemble the robot. This circuit diagram was not intended to be as formal as a complete schematic using proper technical symbols and representations throughout while still introducing the connections that needed to be made between components. Additionally, students were provided with step-by-step directions for assembly and photos of the robot at each stage of development. This circuit is designed to allow the mobile robot to travel in the forward direction whenever the switch is closed and does not contain any logic to recover from a collision or to avoid obstacles.

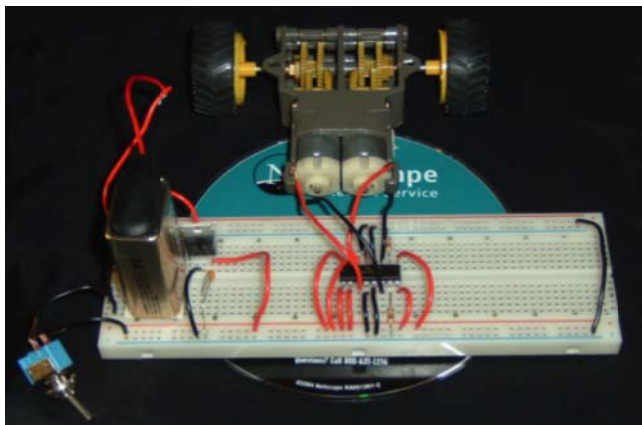

FIGURE 1

THE MOBILE ROBOT BUILT BY STUDENTS IN THE MECHATRONICS INITIATIVE

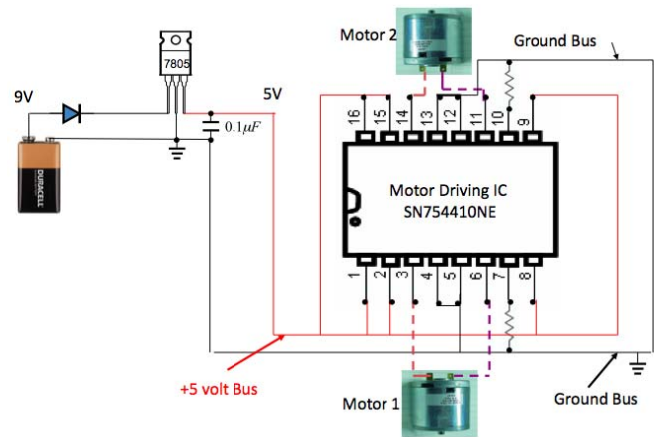

FIGURE 2

THE PSEUDO-SCHEMATIC PROVIDED TO STUDENTS TO BUILD THE ROBOT

The first semester engineering course also introduces all engineers to computer programming. After previously teaching programming using The MathWorks' MATLAB[6] and Carnegie Mellon University's Alice[7], in Spring 2007 the department shifted to using National Instrument's LabVIEW software. Several programming activities have been developed for students to introduce basic computation and digital logic using computer programming. Students are introduced to loops, decision structures, and data plotting algorithms.

One such activity involved simulating a digital controller for a mobile robot. Through this activity students imagined that they had a two-wheeled mobile robot like the one built in the mechatronics workshop and they wanted to add control logic to determine how the motors should be configured in order to react to a collision with an object. In this activity students are informed that two additional switches are mounted on the front of the robot and when a switch is depressed that indicates that a collision has occurred on the corresponding side of the robot. Students use basic Boolean logic gates to determine how to independently control the motors by determining whether the motors on the left and right of the robot should be on in the forward direction, on in the reverse direction, or stopped. Figure 3 depicts how the robot should react to a collision on the right side of the robot. Students determined that in the event of a collision on one side of the robot, the wheel on the side of the robot where the collision occurred should be stopped and the wheel on the opposite side of the robot should be turned on in the reverse direction until the robot has backed away from the collision. In the event of a head-on collision (a collision that depresses both the left and right switches), the control designer can select whether the robot backs up to the right or the left (but not both). If no collision is detected the robot is to continue going in the forward direction with both wheels until the on/off switch is turned off or another collision is detected. All of the inputs and outputs were simulated through Boolean inputs and outputs in LabVIEW and no hardware implementation was done.

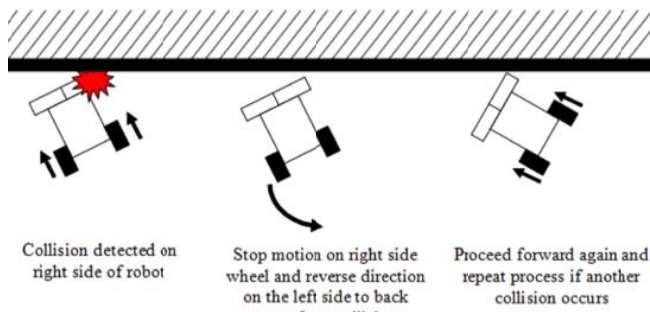

FIGURE 3
INTRODUCING HOW A ROBOT SHOULD RESPOND TO A COLLISION

In Fall 2008 a module was introduced in the course to demonstrate the use of data acquisition (DAQ) modules with LabVIEW. (The ability to easily interface with DAQ modules was one of the motivations of the switch to LabVIEW) Students were shown how to collect data from a motion detector, a force flexion sensor, and a temperature probe. The motion detector collected position data on a ball dropped from a height a few feet about the detector. The temperature probe was warmed by placing it under a running laptop and then cooled by placing it into a glass of cold water. The force flexion sensor was squeezed by hand and responded to the pressure of the grip on the sensor. While other programming activities required students to build their own programs, in this activity students primarily used example programs provided by National Instruments. Figure 4 shows a student dropping a ball onto the motion detector and a teaching assistant showing students the data plot of the temperature rising over time when the probe is placed under a laptop.



FIGURE 4
A STUDENT CAPTURING DATA USING THE MOTION DETECTOR AND A TEACHING ASSISTANT POINTING OUT HOW THE TEMPERATURE ROSE OVER TIME

BLOOM’S TAXONOMY

In 1956, Benjamin Bloom developed Bloom’s taxonomy, a hierarchical categorization of cognition[8]. Bloom’s taxonomy is used to represent the level of understanding a person has of a certain field or set of information. As depicted in Figure 5, the levels of Bloom’s taxonomy from lowest to highest are knowledge, understanding, application, analysis, synthesis, and evaluation. An example of elevating through the various levels of Bloom’s taxonomy is the difference between having memorized an equation

(knowledge), being able to describe what all the terms of an equation are and what the equation really means (understanding), and being able to apply the equation appropriately to solve a problem (application). Many of the activities previously described in this paper do not provide the students with an opportunity to get beyond the levels of “knowledge” or “understanding”. The next section will discuss the development of a hands-on activity designed to promote deeper understanding of mechatronics and programming through the use of a spiral approach within the same course.

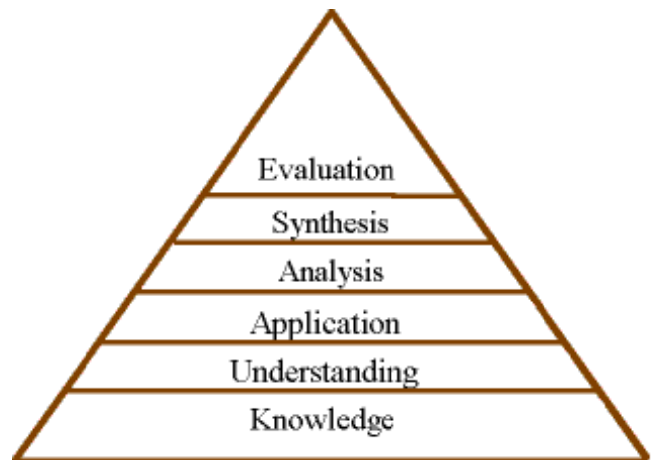

FIGURE 5
THE SIX LEVELS OF BLOOM’S TAXONOMY[9]

ELEVATING STUDENT UNDERSTANDING THROUGH HANDS-ON ACTIVITIES

Through discussions with students regarding the various course activities it was discovered that many students often do not see the relevance of some of the things they are learning in their first semester engineering course. Many first year engineering students do not seem to fully appreciate the interdisciplinary nature of the engineering profession and do not make connections between activities designed to introduce their chosen discipline and activities designed to introduce other disciplines. The mechatronics initiative has been successful in showcasing how mechanical and electrical systems can be integrated in a robot, but many students interested in computer science often do not make connections between the programming initiative and other course units.

In order to allow students to synthesize the information they have learned through the various course units previously described, a second mechatronics hand-on activity has been developed to allow students to build and exercise a more intelligent mobile robot. Through this activity students use a robot that is very similar to the one they built in the first mechatronics activity and use the programming skills they have acquired through the LabVIEW unit in order to develop a digital robot controller that controls the physical movement of a robot based upon

input from a motion detector. The follow subsections describe the various components of this activity and how they are related to the various levels of Bloom's taxonomy.

I. Pre-workshop Assignment

In the first mechatronics activity the students were introduced to various electronic components and shown how to assemble the components into a circuit used to drive a mobile robot. In survey data taken at the end of the mechatronics unit it was determined that many students (25%) simply built the circuit without giving much thought to what the components were really doing in the circuit and why the circuit was designed the way it was. This is understandable because many of the implementation details were hidden from the students in order to reduce the complexity of the activity and the assembly instructions provided clear step-by-step photos of the assembly process without much need for students to completely grasp what each component was doing in order to complete assembly.

A pre-workshop homework assignment was developed for the students to complete after they have completed the first mechatronics unit and before they participate in this second workshop. This homework assignment introduces the students to the datasheet for the h-bridge chip and allows students to determine the functionality of each pin on the integrated circuit. Students are asked to use the datasheet to determine the overall purpose of the h-bridge and the functionality of each of the pins (understanding). Students are then given the h-bridge portion of the circuit depicted in Figure 2 and asked to draw a new circuit diagram representing an appropriate modification such that one of the motors is on in the forward direction and the other motor is on in the reverse direction without disconnecting the motors (application). Students are then asked to think about what would happen if the hard-wired connections on certain control pins were replaced by reconfigurable binary inputs (inputs that can change state from high to low and vice versa). The final problem on this assignment asks to complete a truth table showing which combinations of input states will result in the left and right motors being either stopped or in motion in the forward or reverse direction.

II. In-Workshop Assignment

When students arrive at the workshop, the instructor goes over the homework to make sure students understood how the h-bridge works and the effect of configurable binary inputs on some of the control pins. The students then work individually to fill in a truth table regarding how to configure the motors in the forward, reverse, and stop condition. The instructor can collect the students' work in order to determine that the students understand the truth table before they proceed to the design activity.

In this workshop students are provided the robot shown in Figure 6. The motion detector (green) is mounted to the top of the control circuit and the DAQ module (white) is strapped to the top of the motion detector. The DAQ

module is connected to the student's laptop via a USB cable. This robot uses nearly the same control circuitry and mechanical hardware as the robot built in the first mechatronics workshop, but a stronger gearbox has been used in order to accommodate the added weight of the DAQ module and the motion detector.

The data flow is depicted for students showcasing how information comes in from the motion detector, is processed by the DAQ module, signals are sent to the laptop computer attached to the DAQ module, data is processed, and binary signals are sent out through the binary ports on the DAQ module in order to control the motion of the robot based on its distance from the nearest obstacle. Students work on developing the code to control the robot and when they think they have a working LabVIEW VI they connect their laptop to the robot and determine if it behaves as expected. Students are told that in this workshop they will program the robot to move forward if there is no obstacle within 40 cm of the robot, it will move backwards if there is an obstacle within 30 cm of the robot, and if the nearest object is between 30 and 40 cm then the robot will stop. The instructor then reminds students of the DAQ activity they previously participated in using the motion detector. A skeleton LabVIEW VI containing some of the required control structures is provided to the students and the students are told about the control logic that they must add to the VI in order for the requirements to be met. The skeleton VI provided to the students is depicted in Figure 7. The primary portion the students are responsible for adding is control logic to configure the appropriate binary outputs based on the distance read in from the sensor.

The program is actually not much more complex than the skeleton VI that is provided to the students, but the students have to determine how to incorporate an if control structure (implemented as a case structure in LabVIEW), check the distance from the motion detector to any nearby obstacles, and they have to determine what Boolean configurations must be output on the binary output pins in order to generate the proper motion (forward, reverse, or stopped on both motors) based on the distance to the nearest obstacle using their knowledge of circuits, computer programming, and how sensors work (synthesis).

This workshop and the corresponding pre-workshop assignment were successfully deployed for the first time in Spring 2009. In a survey at the end of the course, students were asked about the difficulty of the pre-workshop assignment and the workshop itself. Students were asked to rate the pre-workshop assignment as too easy, challenging but able to be completed, or too hard. Of those responding to the survey, 10% stated it was too easy, 48% stated it was challenging but able to be completed, and 37% stated it was too difficult (n=60). When asked to provide the same rating regarding the assignment in workshop, the results were similar with 10% responding that it was too easy, 52% responding that it was challenging but able to be completed, and 22% stating it was too difficult (n=60). On the same survey students were asked about their experience with the

two mechatronics units and what could be done to improve them. The responses varied with some students enjoying the free exploration of the data sheet to find out how the component worked and other students feeling that more guidance was necessary in order to understand how the h-bridge worked in the second mechatronics unit.

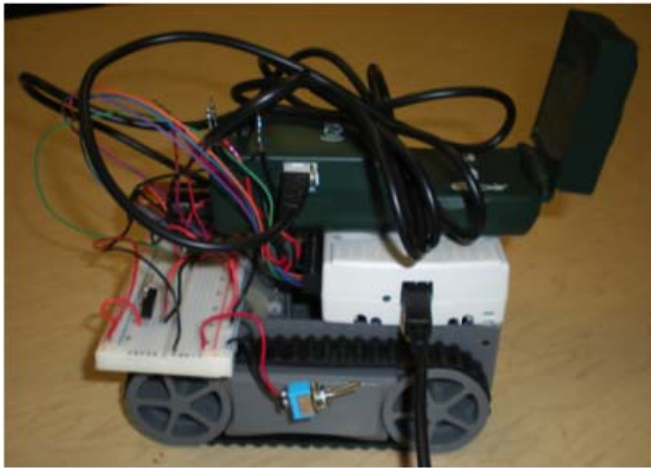

FIGURE 6

THE MOBILE ROBOT SUPPLIED TO THE STUDENTS FOR THIS HANDS-ON ACTIVITY

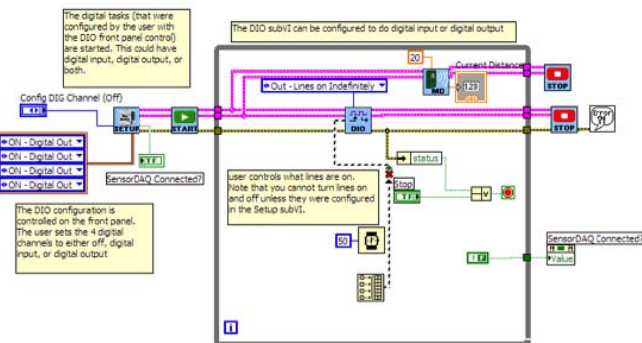

FIGURE 7

THE SKELETON LABVIEW VI PROVIDED TO THE STUDENT

CONCLUSIONS AND FUTURE WORK

This paper has presented several hands-on activities designed to facilitate learning of the basic concepts in mechanics, circuits, digital logic, and computer programming. The activities have been designed with the intent of creating a spiral curriculum such that topics are revisited and the students' level of understanding increases

or solidifies after each activity. Students have responded positively to these hands-on activities and it is the intent of the authors to continue development of more hands-on activities while refining the existing ones based upon student feedback and assessment of student understanding of the various mechanical and electronic concepts. Based upon preliminary feedback, the second mechatronics assignment may need to be revised in order to provide clearer explanations of some terminology and the assignment expectations.

ACKNOWLEDGMENT

The authors would like to thank the National Science Foundation for their generous support through DLR Grant No. 0431779.

REFERENCES

- [1] F. R. Wilson, *The hand : How its use shapes the brain, language, and human culture*, 1st ed. New York: Pantheon Books, 1998.
- [2] A. Spence, "Closing the science gap by hand," in *Education Week*, 27 ed, 2008, pp. 25-27.
- [3] National Science Board, "Science and engineering indicators 2008," 2008.
- [4] Virginia Tech Department of Engineering Education. *Department-level reform* [Online]. Available: <http://www.dlr.engr.vt.edu/>
- [5] J. S. Bruner, *The process of education*. Cambridge,: Harvard University Press, 1960.
- [6] The MathWorks. *Matlab-the language of technical computing* [Online]. Available: <http://www.mathworks.com/products/matlab/>
- [7] Carnegie Mellon University. *Alice: An educational software that teaches students computer programming in a 3d environment* [Online]. Available:
- [8] B. S. Bloom, *Taxonomy of educational objectives : The classification of educational goals*. New York: D. McKay Co., Inc., 1956.
- [9] *Bloom's taxonomy* [Online]. Available: <http://www.officeport.com/edu/blooms.htm>

AUTHOR INFORMATION

Ricky Castles Ph.D. Candidate, Bradley Department of Electrical and Computer Engineering, Virginia Tech, rcastles@vt.edu.

Vinod K. Lohani, Associate Professor, Department of Engineering Education, Virginia Tech, vlohani@vt.edu

Pushkin Kachroo, Professor, Department of Electrical and Computer Engineering, University of Nevada at Las Vegas, pushkin@unlv.edu