

Microprocessors: From Theory to Practice, a Didactic Experience

Edson Pedro Ferlin¹, Valfredo Pilla Júnior²

Computer Engineering Department, Centro Universitário Positivo – UnicenP,
Rua Prof. Pedro Viriato Parigot de Souza, 5300, Curitiba, PR, Brazil, 81280-330

Abstract - The study of microprocessors in Computer or Electronic Engineering Programs faces a great problem: the migration from theory to practice, from the abstract concepts to laboratory experimentation. In this work we present the learning methodology adopted by us in the last years in the Microprocessor Course. In this methodology the student is driven from the classroom theory to laboratory experimentation. Several tools are applied, as the hardware description language for microcomputers systems modeling and FPGA implementations, microcontroller experiments based on proto-o-board assemblies and more complex microprocessor applications based on electronics kits previously developed in the Computer Engineering Program. This methodology applied in this course has been gradually improved through the time, and the improvement process continues, although we believe to have reached a format that integrates theory and practice, where the students have control of the process, involving microprocessors and its applications.

Index Terms - Computer Engineering, Methodology Microprocessors.

INTRODUCTION

The Computer Engineering Program at UnicenP [1] has an annual serial structure. The Program is developed in four years (morning program) and five years (nocturnal program). The school year is divided in four periods of one bimester, totalizing 200 days of classes. In each bimester the student receives an evaluation score, from 0 to 10, and at the end of year the scores of arithmetic mean must be superior to 7.0 with a minimum frequency of 75% for course approval; if the student does not obtain the average but has a performance between 4.0 and 6.9 he / she can make a last evaluation. For the student be successful in this evaluation he / she must have a new average, calculated for the arithmetic mean between the last evaluation and the original average, and this average must be equal or superior to 5.0 for approbation.

The curricular structure congregates the courses of the program in two great areas of Professional Formation (hardware and software areas) [2], courses in Basic Formation area (Calculus, Physics, and others), curses of Human Formation area (Human and Social Sciences), Management

Formation (Enterprise Management and Management of Projects) and Specialty Formation. The Microprocessors course (hardware area) occurs in the third year. This course has a total duration of 160 hours in class, for both theory and practice. Two courses supplies the fundamentals for the Microprocessors course: the Digital Systems and the Computer Architecture and Organization courses. These two courses have collaborated between itself through an integration process based on concomitant and complementary contents development, experience sharing and common final projects [3]. This integration produces some consequences in the Microprocessors course, with the adjustment of contents and the possibility of development of more advanced projects. Some of learning improvement presented in others courses, as Electronic Instrumentation and Graduation Thesis [4], is a result of the application of the acquired knowledge from Microprocessors.

The main problems in the learning in Microprocessors course are found in the relationship between the theory and the practice, a consequence of the natural understanding difficulty, by the students, of the aspects of project of architectures of the necessary hardware and software for solution of problems and, mainly, of the interaction between these architectures. The motivation of the students also requires attention, despite of wide range of practical application of the knowledge of this discipline, the initial difficulties many times produce frustrations that are reflected in the academic performance.

In this work we present the methodology applied to the Microprocessors Course of the Computer Engineering Program at UnicenP. Initially we described the objectives to be reached by means of our approach and its integration with the Digital Systems and Computer Architecture and Organization courses. Later, we present the methodology and strategies used in the development of the course. Finally, we evaluate the results and we comment our future plans for this course.

OBJECTIVES OF THE METHODOLOGY

The main objective searched for our approach is the increase of the students' understanding of the principles that guide the construction of engineering solutions based in microprocessed systems. The approach is of the construction of dedicated systems that interact with peripherals and others dedicated systems.

¹Edson Pedro Ferlin, Chair, Computer Engineering Department, Centro Universitário Positivo – UnicenP, ferlin@unicenp.br

²Valfredo Pilla Junior, Professor, Computer Engineering Department, Centro Universitário Positivo – UnicenP, vpilla@unicenp.br

As consequence of this understanding, is desired that the student be capable to project solutions for specific problems, demonstrating full domain of the theory and the practice.

Still, we consider very important the growth of the student motivation, which results in better academic performance in this course and in the others, as the Electronic Instrumentation course and the Graduation Thesis course, that use of the knowledge acquired in the Microprocessors course.

COURSE REVIEW

The experiences and projects constitute the key-point in the process of learning in this course. Thus, we present below a historical summary of these activities before presenting the course current organization.

The Microprocessors course occurred for the first time in the year of 2001. In this year the practical activities involved a prototype of four bits CISC (Complex Instruction Set Computer) microprocessor developed with Hardware Description Language and tested by simulation [5]. An entire semester was dedicated to the study of 8051 microcontroller, including a set of experiences (commented later) and a course final project based in this processor. In the year of 2002 the test in the hardware was added to the project of processor CISC. A FPGA device was configured with this project for these tests [6]. In the year of 2003 the CISC processor was replaced by RISC (Reduced Instruction Set Computer) [7], which included hardware tests. The CISC processor was destined to the final project of Digital Systems course. In this year of 2004 the project of a compiler for this processor RISC will be incorporated with an instruction set extension a more complex hardware validation. The compiler will be developed in Compilers course, with occur concomitantly to Microprocessors course. The project with microcontroller will be dedicated to the construction of systems of instrumentation to be used in Electronic Instrumentation course.

THE COURSE

The focus of Microprocessors course is the project of dedicated systems; in these computers the processors are microcontrollers. Topics related to computer organization of general purpose or computers for high performance applications are also studied. Thus, the functional architectures examples are mainly based in 8051 microcontroller (main topic of the course in its second semester). Others architectures as the x86 family, Power PC and others RISC and CISC commercial processors are used as additional illustrative examples.

The course begins with a revision of the general digital computer and processor organization, being distinguished its applications categories. After this introduction, the computer is studied through its pieces. The semiconductor memory devices, the study of compatibility between memory and processor, and memory bank building are studied for generic processors and for the 8051. The students develop a laboratory experiment, in with a memory bank is projected and assembled in proto-o-boards for tests. In this experiment are still verified the dynamic proprieties of semiconductor

memories devices, as access timing. The students should develop the test setup.

Before continuing with the course specific contents is done a review of digital logic (Digital Systems course contents) with use as examples processor internal structures as registers, arithmetic and logic units, multiplexers circuits, counters and auxiliary circuits as the clock generator. After this revision, is studied the processor microarchitecture (Computer Architecture and Organization course content) in a hardware point of view. Are studied the operative and control internal parts, the instruction execution managed by the control unit, the instruction categories and addressing modes.

Complementing this study a RISC processor project is developed with Hardware Description Language (HDL). We choose the AHDL language (Altera Hardware Description Language), a subset of the standard language VHDL (VHSIC Hardware Description Language) [8]. We decided by this language because it is easy to learn (it is intensively applied in Digital Systems course) [9]; our main objective is to develop the digital hardware synthesis skills and the use of an easy tool allow effort concentration in the development, not in the tool.

After a modular development of the architecture, the modules are integrated. The final tests are done by simulation in the integrated development tool and finally by hardware test. For this purpose, test software should be assembled from the language of the projected machine and submitted to the processor. This software should demonstrate the fully processor functionality. The processor is implemented in a FPGA (Field Programmable Gate Array) of an educational UPI Altera kit, and is embedded in the projected memory system, besides a basic interface system that allows a minimum level of human-device interaction.

The figure 1 presents the block diagram of the RISC processor used in 2003 [6]. The table 1 shows the reduced instruction set developed. This project was a fully success: all the teams had gotten complete functionality in its projects.

After the project conclusion are presented the architectures of input / output interfaces, as interruption, and structures applied for system performance improvement by timing or functional parallelism, as pipelining and superscalar, besides high performance memory system (cache). Finally are presented the structure of system protection, the watchdog timer.

Finishing this studies, some commercial processors CISC, RISC e VLIW / EPIC are studied, closing the first semester course activities.

The second semester of Microprocessors course is dedicated to the detailed study of the internal and external architecture of 8051 microcontroller, its machine cycles, specific characteristics as interruption system, serial and parallel interfaces, timers and counters, besides its assembly language. The study of theory is complemented by a set of experiments.

These experiments are based in a minimum system with increasing complexity. The teams formed by two students each should develop the experiments exclusively by means a

proto-o-board assembly. The teams have two weeks (eight hours in classroom) to complete every experiment.

In the first experiment the 8051 processor must receive the clock and reset circuit, external program memory, push-buttons as input peripherals, leds and display of seven segments as output peripherals. One specification of software for system test must be implemented, foreseeing timing reactions. The second experiment adds to the system an external SRAM with its verification routine. The third experiment adds one serial interface for a basic communication protocol with one personal computer. A liquid crystal display used for system status completes the experiment. In the fourth experiment includes analog to digital and digital do analog interfaces, both memory mapped.

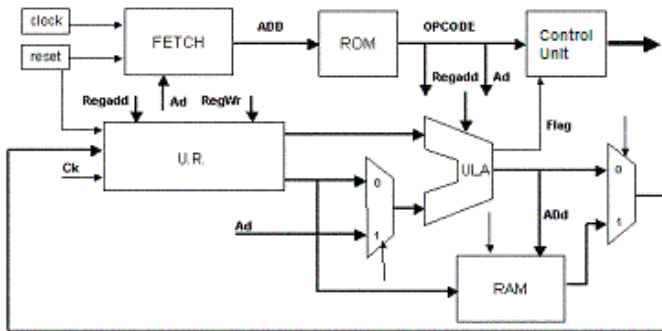

FIGURE 1

RISC PROCESSOR ARCHITECTURE DEVELOPED IN 2003 IN MICROPROCESSORS COURSE.

The assembly process is based on proto-o-boards, because it has as objective to become the planning and the documentation of project essential parts of the activity. The teams must develop a schematic diagram elaborated to serve as reference in the assembly. Still, the distribution of the components in proto-o-board must be carefully planned for the future expansion. The electric and visual quality of the assembly is also evaluated. The program of test developed from the basic specification must be documented.

The second semester is concluded with a final project. In this project all the system components previously experimented must be present. This project can be developed in association with another course and must provide a complete solution based on microcontroller. It is not required the use of the 8051 microcontroller; the team is free to choice the processor. But, if the team makes this choice it will be able to make use of a circuit board designed as a basic system. The course of the activity is evaluated in form of phases of project that contribute gradually for the composition of the note of evaluation of the project.

The figure 2 presents an example of final project that used another processor, the PIC from Microchip. It was a digital scope with its own liquid crystal graphic display for a standalone operation.

Several electronic kits were developed in Computer Engineering Program, as example the minimal system 8051, the interface circuit with liquid crystal display, and the interface circuit with analog-digital and digital-analog

conversion. A view of these modules é showed in figure 3. These kits intend to give agility to final project development, therefore the student can use these circuits in its project, has since already they had studied previously, in the course, reducing the time of development and assembly of the prototype; and this time that was saved is destined for the application in itself, making possible that the student develops one project / prototype with a bigger aggregate value, allowing a bigger multidisciplinary and, beyond the practical implementation of the theories studied in the project.

TABLE 1
INSTRUCTION SET OF RISC PROCESSOR FROM FIGURE 1

Instruction (mnemonic)	Action	
ADD Rd, Rs, Rt	ROM[PC] Rd ← Rs + Rt PC ← PC + 1	Opcode Fetch Execution PC Adjust
SUB Rd, Rs, Rt	ROM[PC] Rd ← Rs - Rt PC ← PC + 1	Opcode Fetch Execution PC Adjust
OR Rd, Rs, Rt	ROM[PC] Rd ← Rs v Rt PC ← PC + 1	Opcode Fetch Execution PC Adjust
LOAD Rt, Rs, Imm8	ROM[PC] Rt ← RAM[Rs + Imm8] PC ← PC + 1	Opcode Fetch Execution PC Adjust
STORE Rt, Rs, Imm8	ROM[PC] RAM[Rs + Imm8] ← Rt PC ← PC + 1	Opcode Fetch Execution PC Adjust
BRANCH_EQ Rs, Rt, Imm8	ROM[PC] Rs - Rt PC ← !ZERO & (PC + 1) + ZERO & (PC + 1 + Imm8)	Opcode Fetch Execution PC Adjust
JUMP Imm8	ROM[PC] PC ← PC + 1 + Imm8	Opcode Fetch Execution PC Adjust

CONCLUSION

In the present days it is evidenced that an approach more directed to the know to make, making possible that the student tries and produces new knowledge, taking for base the knowledge acquired for the theory (in classroom) and tested / experimented (in laboratory). But this only begins to have concrete effect when the student lives deeply the problem and interacts with the solution in the practical, therefore it is using one more way of acquisition of knowledge that is in result of this practical experience, also developing the psychomotor skills. The four pillars of the education are to learn to know, to learn to make, to learn to live together and to learn to be. When the theory works with the practice, it develops the learning in these pillars, therefore the student acquires the knowledge, makes it solid in the practice, works the relationship with other students and professor, beyond to acquire the auto-confidence for the solution of the problems and also on proper itself.

We can verify a significant improvement on the part of the students in AVIN [10] (Integrated Evaluation), because the students obtain good solutions in the questions that involve the knowledge of Microprocessors; and in the Graduation Thesis, where the students apply the microprocessors knowledge for

its projects implementations, almost all the projects uses a microprocessor.

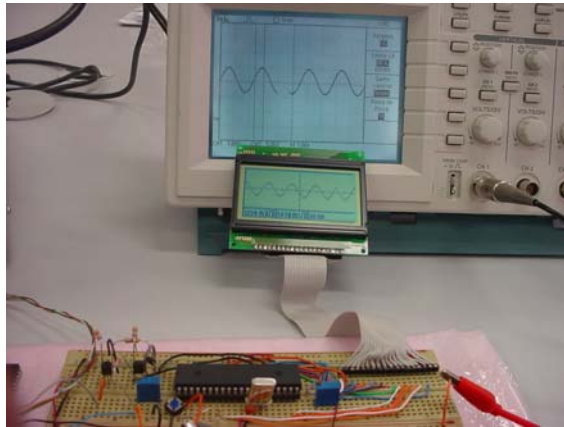

FIGURE 2

EXAMPLE OF FINAL PROJECT IN MICROPROCESSORS COURSE: A DIGITAL SCOPE FOR STANDALONE OPERATION.

The next planned steps for the teach-learning process improvement in Microprocessors includes an increase of both instruction set and RISC processor architecture structured in FPGAs. Based in this advance, it will be developed an algorithmic language and compiler, that it will allow the use of this microprocessor in others applications, for example, in course of Digital Processing of Signals and others projects.



FIGURE 3

BASIC SYSTEM WITH MICROCONTROLLER 8051 AND PERIPHERALS KITS.

REFERENCES

- [1] Tozzi, M. J., Dziedzic, M., Ferlin, E. P., Nitsch, J. C., Rodacoski, M., "Os Cursos de Engenharia do UnicenP", In: *COBENGE 1999 - XXVII Congresso Brasileiro de Ensino em Engenharia*, 1999, Natal - RN - Brasil., 1999, pp. 2662-2669.
- [2] Ferlin, E. P. "Use of Multidisciplinary in Undergraduate Computer Engineering in the Courses of the Digital Area", In: *FIE 1999 - 29RD ASEE/IEEE Frontiers in Education Conference*, 1999, San Juan. 1999, v. 12a9, p. 45-48.
- [3] Pilla Junior, V., Ferlin, E. P., Cunha, J. C., Gonçalves, M. M., "A Integração de Disciplinas na Linha de Hardware no Curso de Engenharia da Computação do UnicenP", In: *COBENGE 2003 - XXXI Congresso Brasileiro de Ensino em Engenharia*, 2003, Rio de Janeiro, 2003.
- [4] Ferlin, E. P., Pilla Junior, V., Ferlin, E. P., Cunha, J. C., "The Graduation Thesis in the Computer Engineering Program at UnicenP". In: *FIE 2003 - 33RD ASEE/IEEE Frontiers in Education Conference*, 2003, Boulder - CO - USA, 2003.
- [5] Ferlin, E. P., "The Project of a Didatic CPU for Multidisciplinary", In: *ICEE 1999 - International Conference on Engineering Education*, 1999, Praga and Ostrava. 1999.
- [6] Ferlin, E. P., "Utilização de Novas Tecnologias na Graduação em Engenharia da Computação", In: *COBENGE 1999 - XXVII Congresso Brasileiro de Ensino em Engenharia*, 1999, Natal - RN - Brasil. 1999. p. 1228-1233.
- [7] Cichaczewski, E. , Przysienzny, E. T, Pilla Junior, V., Ferlin, E. P., "Microprocessador RISC implementado em Lógica Programável", In: *PIBIC 2003 - VIII Seminário de Iniciação Científica e Tecnológica*, 2003, Curitiba. 2003.
- [8] Pilla Junior, V., Ferlin, E. P., Cunha, J. C., "O Ensino de Projetos Digitais: Fundamentação Teórica, Práticas de Laboratório e a Tecnologia de Dispositivos Reconfiguráveis", In: *WCETE- 2004 - World Congress on Engineering and Technology Education*, 2004, Guarujá/Santos, Brazil, 2004.
- [9] Ferlin, E. P. Eleutério, M. A. M., "Vantagens na Elaboração de Projetos Digitais Utilizando Dispositivos Lógicos Programáveis", In: *SPET 1998 - IV Simpósio de Pesquisa e Extensão em Tecnologia*, 1998, Natal - RN - Brasil. 1998, p. 188-190.
- [10] Ferlin, E. P., Tozzi, M. J., "First Integrated Examination of the Computer Engineering Program", In: *FIE 2002 - 32RD ASEE/IEEE Frontiers in Education Conference*, 2002, Boston, 2002.